

Mechanical Reasoning

Preparation Guide

This preparation guide helps you prepare for spatial reasoning assessments. It provides guidance on how best to approach the assessment, allowing you to give your best possible performance.

Why are Aptitude Assessments used?

Employers often use aptitude assessments as part of their assessment procedures for the selection and development of staff. Research has shown that they are powerful predictors of performance at work.

Assessments help you to:

- demonstrate your strengths
- be assessed fairly on job relevant criteria
- find out more about your strengths and development needs
- make future career decisions based on your abilities

Assessments help employers to:

- select people best suited to the demands of the job
- identify areas where individuals might benefit from further development
- obtain objective information about people's abilities

Instructions

On the following pages are some practice questions which are similar to those you will be asked in the assessment. Completing these will help you to understand the types of questions used and gain experience in taking ability tests.

This exercise is designed to assess your ability to understand and reason with mechanical principles. You will be presented with a series of drawings, each followed by a question with three answer options. Your task is to choose the best answer to each question from the options given. Answer each question by filling in the option you have chosen on your answer sheet.

When you complete the actual assessment, you will not be able to use erasers to change your answer.

Please see the instructions below on how to indicate your answers:

Instructions for completing the answer sheet:

Press hard and completely fill in the inner circle.

To change an answer, put a cross through the circle you wish to change and then fill in the correct circle.

If you want to change back to your original answer, cross out the incorrect answer and completely fill the outer circle of the previous answer.

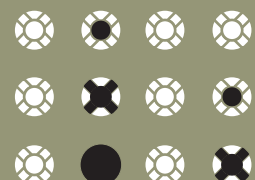

The actual test is strictly timed, so time yourself and try to complete all 4 questions within **90 seconds** to practice working against the clock.

Set a timer for 90 seconds (or note down your start time), turn to page 2 and begin.

1

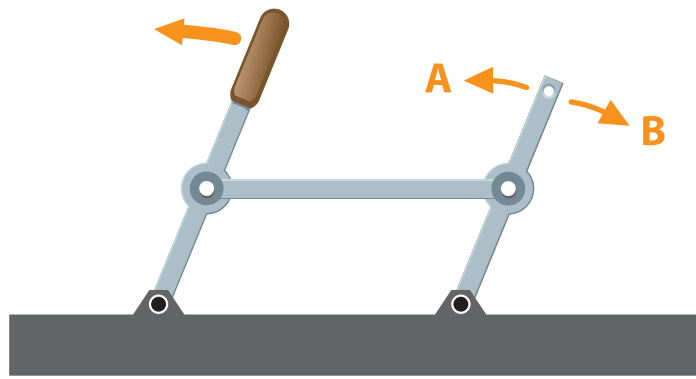

As the handle is pulled, in which direction will the end of the bar move?

- A Direction A
- B Direction B
- C Neither Direction

2

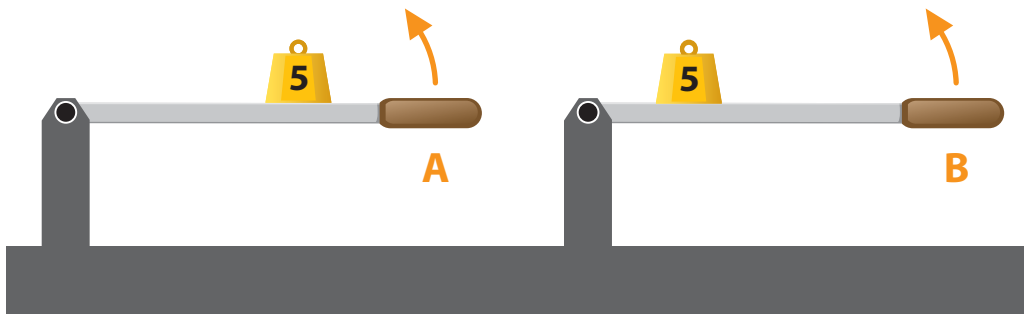

Which handle requires less force to lift?

- A Handle A
- B Handle B
- C Both handles require equal force

3

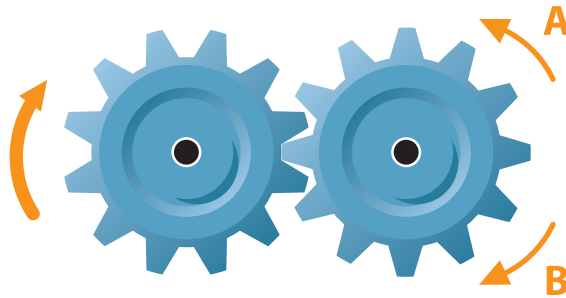

In which direction will the gear turn?

- A Direction A
- B Direction B
- C Neither direction

4

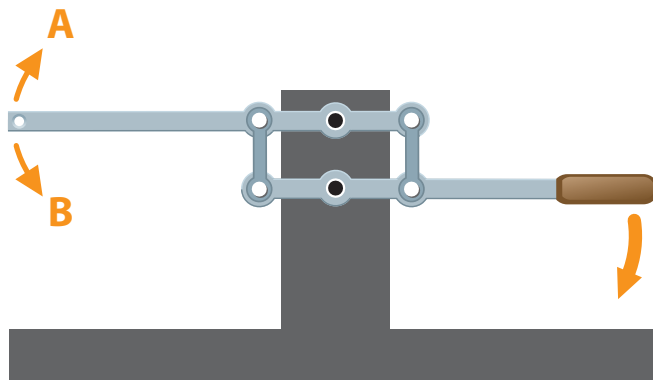

In which direction will the arm swing when the handle is moved as shown?

- A Direction A
- B Direction B
- C Neither direction

Try to answer any questions you did not reach in the time limit before checking your answers.

Checking your Answers

Check your answers against the correct answers at the bottom of this page. Look at any questions you got wrong and try to understand how to arrive at the correct answer. Keep in mind that most ability assessments are designed so that the questions gradually increase in difficulty and that people typically do not complete all of the questions within the time limit. If you took much longer than 90 seconds to answer the questions, try to speed up your work rate. If you finished all of the questions within the time limit but made many mistakes, try focusing more on the accuracy of your responses.

Improving your Mechanical Abilities

The best way to improve your mechanical abilities is by working with technical objects. As well as gaining experience in the assessments themselves, there are several other things you can do to improve your mechanical abilities.

- Work with tools, equipment and machinery.
- Maintain, fix and repair technical objects.
- Read up on physical principles.
- Estimate how objects are going to move.
- Build objects from various materials.
- Look at workshop manuals.
- Make gadgets with engines from various materials.

Before the Session

- Follow the suggestions included in this preparation guide.
- Get a good night's sleep before the assessment.
- Give yourself plenty of time to get to the assessment venue so that you don't have to rush.
- If you wear glasses, contact lenses or a hearing aid, make sure you take them with you.
- If you have any special requirements, e.g. larger print versions of the test, specific lighting or seating needs, it is important that you make these known immediately to allow appropriate accommodations to be made.

During the Assessment Session

- Try to stay calm. Using the practice tips above should help you feel more at ease.
- Listen carefully to the instructions, and ask questions if you are not sure of anything before the assessment starts.
- Read each question carefully.
- Work as quickly as you can. Do not take too much time over any one question.
- If you find a question too difficult or are unsure of an answer indicate your best choice and move on quickly.
- After an assessment always seek feedback. It is much easier to improve your abilities if you know how well you have done.

Good luck in your assessment session. We wish you every success in your career.

Answer Section Correct Answers

	A	B	C	D		A	B	C	D		A	B	C	D		A	B	C	D
1	<input checked="" type="radio"/>	<input type="radio"/>	<input type="radio"/>	<input type="radio"/>	2	<input type="radio"/>	<input checked="" type="radio"/>	<input type="radio"/>	<input type="radio"/>	3	<input checked="" type="radio"/>	<input type="radio"/>	<input type="radio"/>	<input type="radio"/>	4	<input checked="" type="radio"/>	<input type="radio"/>	<input type="radio"/>	<input type="radio"/>